



fisionarte

LIGHTING
ARCHITECTURE

LIGHTING DRAW

Disegnare, colorare, scrivere sono azioni che sin da piccoli viviamo quotidianamente, esperienze naturali e dirette.

Queste azioni, così spontanee e liberatorie, riescono ad esprimere fin da subito il nostro stato d'animo; le nostre emozioni fuoriescono dalle nostre mani per mezzo del tratto e del colore.

LINE e MIKADO sono due lighting-concept realizzati per poter continuare a disegnare ed esprimersi, utilizzando non più pastelli o inchiostro, ma linee di luce che vanno a creare segni luminosi negli ambienti e nelle architetture.

L'essenzialità e la modularità, la personalizzazione delle finiture e del tipo di luce, i molteplici controlli che possono essere utilizzati diventano strumenti con cui illuminare i volumi che ci circondano e donare comfort ai nostri ambienti.

Innovazione e ricerca, predisposizione al cambiamento e anticipazione del futuro sono le linee guida dei nostri servizi professionali e del nostro approccio lavorativo.

Drawing, coloring, writing are actions that we perform daily from an early age, natural and direct experiences.

These actions, so spontaneous and liberating, immediately express our state of mind; our emotions spill out of our hands through strokes and colors.

LINE and MIKADO are two lighting-concepts created so we can keep drawing and expressing ourselves, no longer with pastels or ink, but with lines of light that create luminous signs in environments and architectures.

The essentiality and modularity, the customization of finishes and of the type of light, the multiple controls become tools to illuminate the volumes that surround us and to make our environments comfortable.

Innovation and research, predisposition to change and anticipating the future are the guideline of our professional services and our working approach.

LINE

&

MIKADO



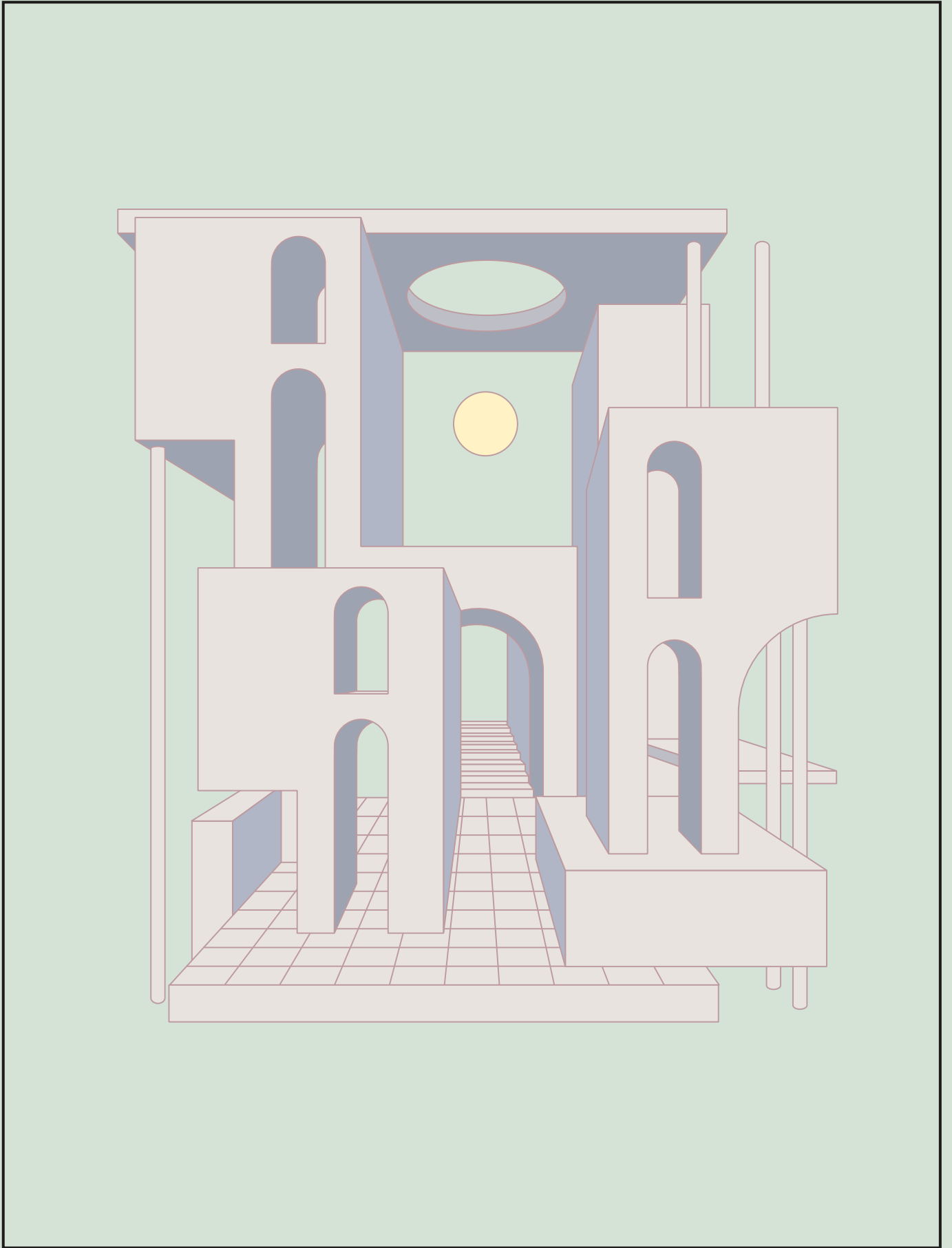

WE NEED SPACE WITH EMOTIONAL QUALITY LIGHT

Più il mondo diventa complesso più dobbiamo essere creativi nell'affrontare sfide in ogni ambito della nostra quotidianità. Il gioco può ispirare la creatività. Il colore può influenzare lo spazio toccando l'emotività. La luce può disegnare le forme, accompagnando ogni momento della giornata in modo peculiare, assecondando la nostra natura e le nostre necessità.

The more the world becomes complex, the more creative we need to be in the way we face its challenges and in every area of our daily life. Play can inspire creativity. Color can affect space by touching us emotionally. Light can draw shapes during every moment of the day in a peculiar way following our nature and our needs.



LINE





LINE



LINE architecture

La luce è un elemento naturale base, fondamentale per la nostra vita e il nostro benessere psicofisico. Nonostante la sua costante presenza, spesso passa inosservata. Eppure c'è.

Il sistema LINE nella sua semplicità e nel suo minimalismo è proprio questo, una sorgente di luce quasi invisibile, eterea ma reale.

Leggeri raggi di luce che evidenziano le geometrie architettoniche senza invaderle, un tratto pittorico più che uno strumento, per valorizzare gli spazi del nostro vivere.

Le molteplici fotometrie disponibili sono un mezzo indispensabile per il raggiungimento dell'obiettivo emozionale di LINE.

Light is a basic natural element, essential to our life and psychophysical well-being. Despite its constant presence, it often goes unnoticed. Yet, it is there.

The LINE system, in its simplicity and minimalism, is just that: an almost invisible light source, ethereal but real.

Thin light rays that highlight the architectural geometries without invading them, a pictorial trait rather than a tool, to enhance the spaces of our life.

The various photometries available are an indispensable means of achieving LINE's emotional goal.

Horizontal system_Down light



Wall+ceiling system_Indirect light





Wall system_Indirect light

LINE art

Non geometrie tridimensionali ma tracce leggere, prospettive di luce invisibili che si inseriscono plasmandosi in ogni contesto, valorizzando gli ambienti e conservandone la loro natura.

L'essenzialità del segno, l'invisibilità del sistema LINE e le infinite possibilità di scelta di luce applicabile permettono la realizzazione di scenografie minimali ma di grande impatto emozionale.

L'ambiente e ciò che quest'ultimo custodisce diventano protagonisti grazie al sistema LINE, dando evidenza a ciò che ci circonda; una sinergia che si presta perfettamente alle delicate e preziose realtà museali e artistiche.

La domotica applicabile a LINE ne fa un sistema flessibile e adattabile a ogni tipo di ambiente ed esigenza illuminotecnica.

Not three-dimensional geometries but light traces, invisible light perspectives that fit into any context, enhancing the environments and preserving their nature.

The essentiality of the stroke, the invisibility of the LINE system and the endless possibilities of applicable lights allow the creation of minimal but highly emotional settings.

The environment and what it contains become protagonists thanks to the LINE system, which enhances our surroundings; a synergy that works perfectly in the most delicate and precious realities, like museums and artistic locations.

The home automation applicable to LINE makes it a flexible system that works in any type of environment and with any type of lighting requirement.

Horizontal system_Down light



Ceiling system_Down light
Wall system_Down light



MÅN

– fra den indre verden til det ydre rum

THE MOON

– From Inner Worlds to Outer Space

VENEN



Ceiling system_Indirect light



Ceiling system_Double emission light
Wall system_Indirect light

LINE lifestyle

Il comfort negli ambienti domestici non è dato solo dall'arredo.

LINE con la sua assoluta semplicità non invasiva e la luce diffusa crea giochi di luce dalla memoria ancestrale, ricordandoci immediatamente il calore di ciò che chiamiamo casa.

Valorizzare gli ambienti a noi più cari non con oggetti luminosi ma con tratti di luce invisibili, lasciare lo spazio libero ai volumi, scegliere l'illuminazione corretta per ciascuna location.

LINE con la soluzione bianco dinamico ci fa ripercorrere l'evolvere del giorno, creando in ciascun momento la giusta atmosfera.

Poter gestire la luce in remoto, senza lasciare il comfort momentaneo, è ora possibile tramite il sistema con telecomando o app.

Comfort in domestic environments is not only created by furnishings. LINE, with its non-invasive simplicity and diffused light, creates plays of light of ancestral memory, immediately reminding us of the warmth we feel at home.

To enhance the environments most dear to us by using not light elements but invisible light strokes, to open space to volumes, to find the right lighting for each location.

LINE, with its dynamic white solution, follows the daylight and creates the right atmosphere in every moment.

The control system, with app or remote, allows us to manage the light from a distance, without leaving momentary comfort.



Sloping roof system_Indirect light

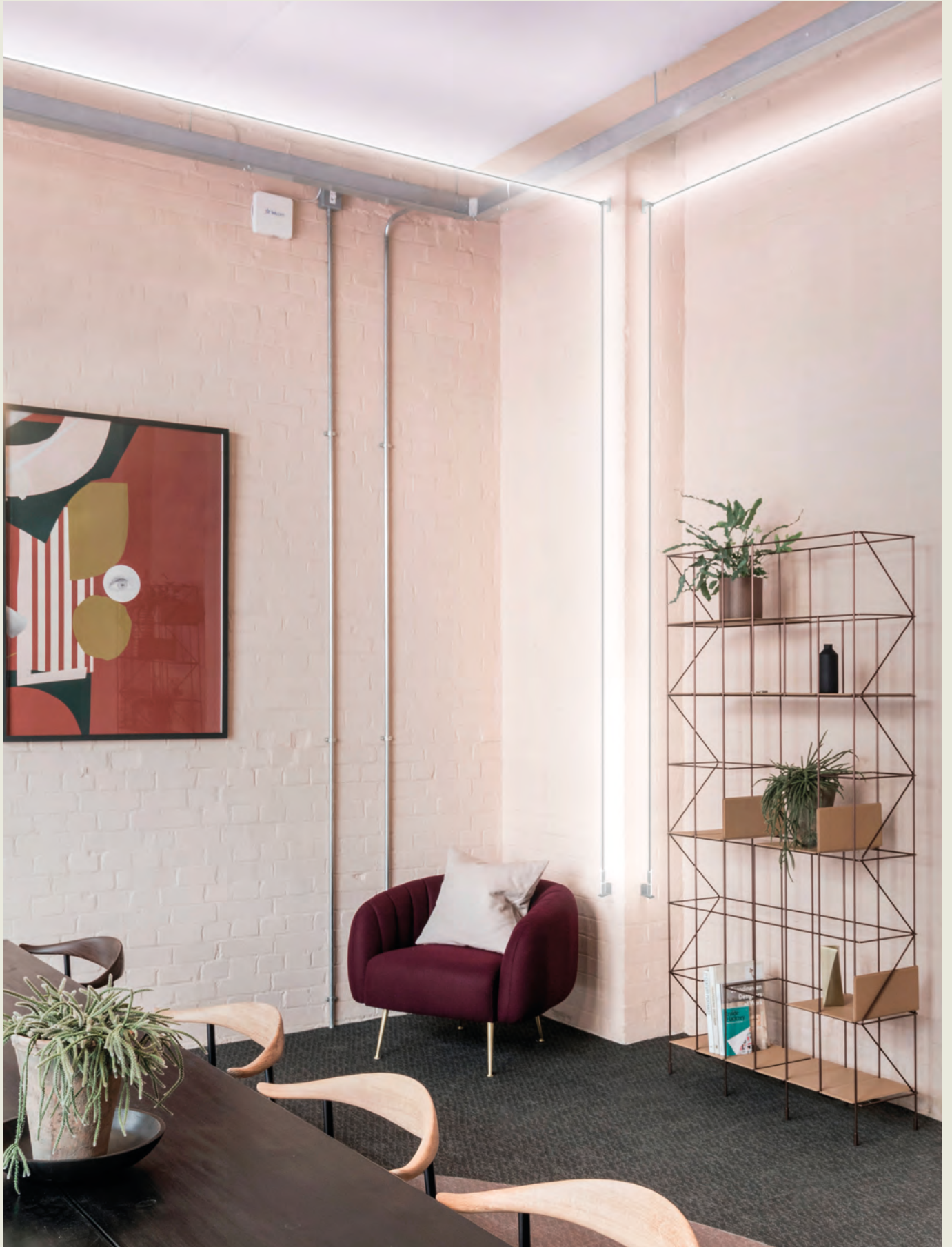

Wall perimetral system_Indirect light



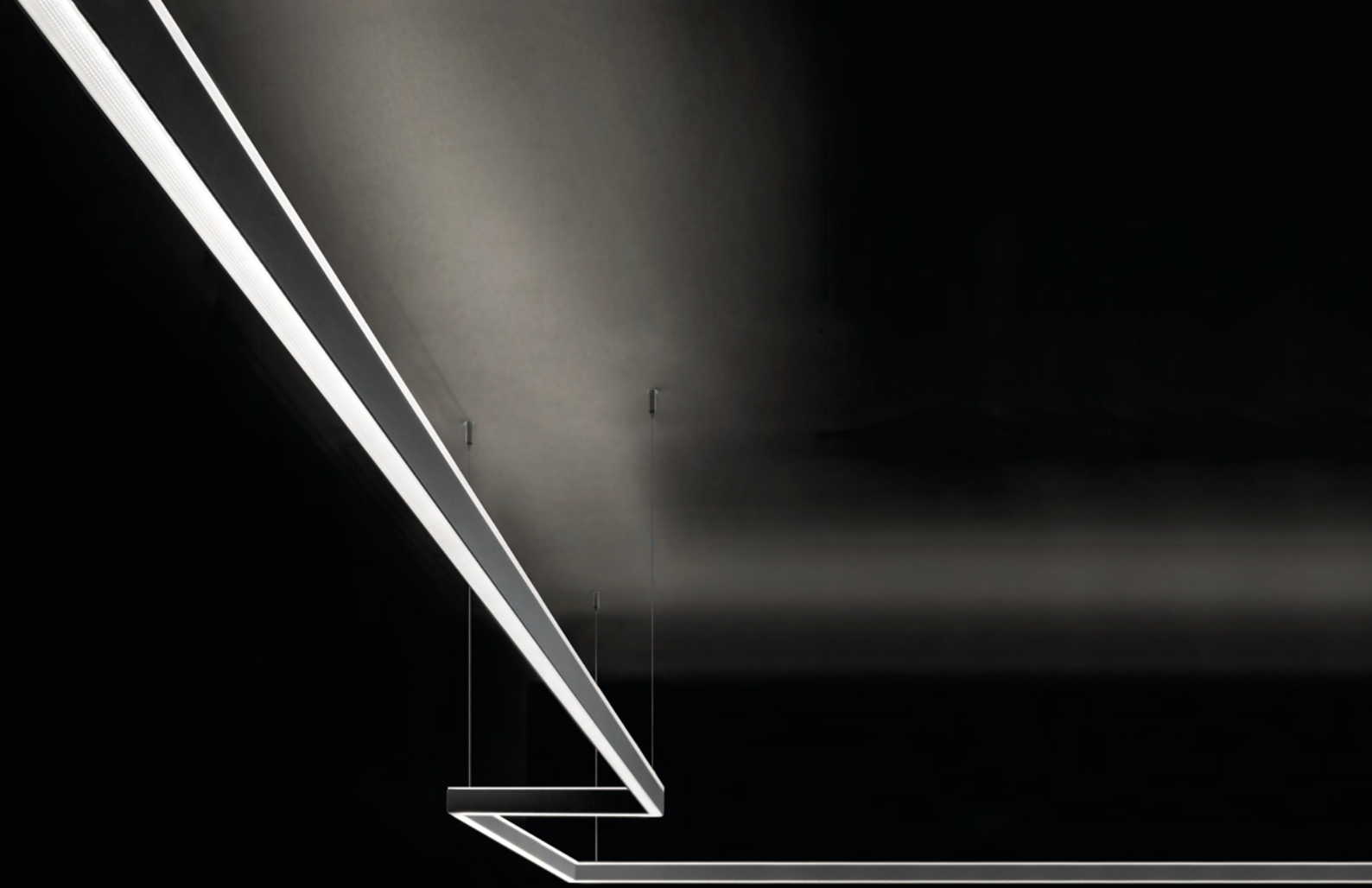

MIKADO



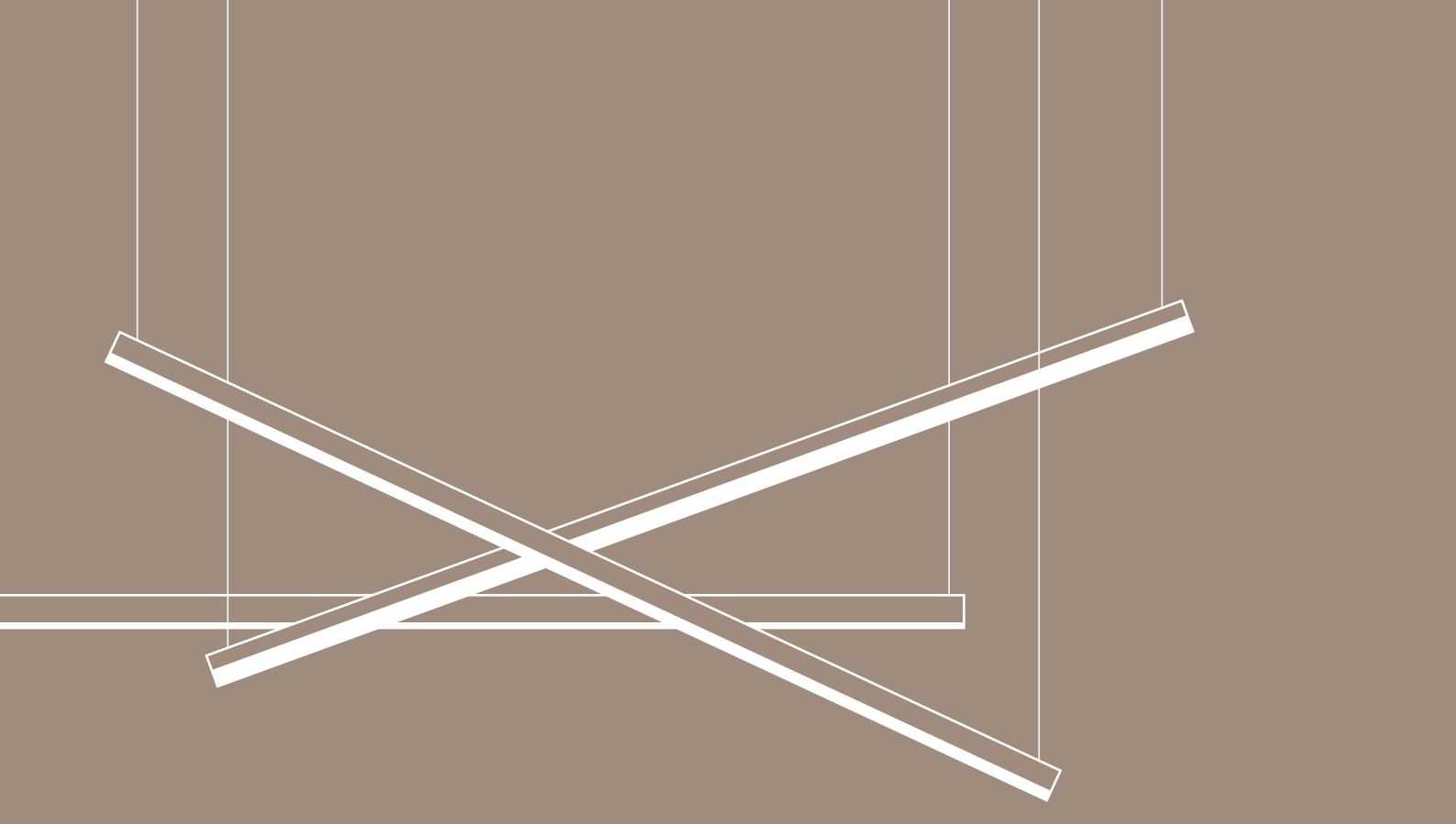

MIKADO



MIKADO lifestyle

Architettura e illuminazione si fondono in un tutt'uno nell'ambiente che ci accoglie.

MIKADO è elemento lineare, non invasivo, che ricerca l'essenzialità delle linee pulite e minimali, la forza delle geometrie.

Tutto questo rende MIKADO un elemento che valorizza i nostri ambienti personali, donando benessere e comfort ambientale grazie anche alla modularità d'illuminazione "Bianco dinamico".

La soluzione d'illuminazione "RGB", invece, fa di MIKADO un prodotto distintivo e ancor più personalizzabile per i nostri ambienti personali, giocando con le molteplici sfumature di colore della luce.

L'essenzialità delle linee pulite e minimali, con la forza delle geometrie, rendono MIKADO un elemento che valorizza i nostri spazi personali.

Architecture and lighting merge into one in an environment that welcomes us. Mikado is a linear, non-invasive element that seeks essentiality in clean and minimal lines and in geometries.

For these reasons, MIKADO is an element that enhances our personal environments, while creating occupant well-being and environmental comfort.

This also thanks to the modularity of "dynamic white" lighting.

The "RGB" lighting solution, on the other hand, makes MIKADO a distinctive and even more customizable product, for our personal environments, playing with the multiple color shades of the light.

The essentiality of clean and minimal lines and the power of geometries make MIKADO an element that enhances our personal spaces.



1x100 cm_Down light



3x100 cm_Double emission light



Custom 1x50 cm_Double emission light

MIKADO workspace

Geometrie essenziali, leggerezza della forma, minimalismo e pulizia delle linee, infinite personalizzazioni offrono la possibilità di arredare tutti gli ambienti professionali.

MIKADO nasce anche per decorare ambienti tecnici senza forzature e rispettando le esigenze lavorative.

Un'esile linea di luce che, forte della sua tecnicità e prestazioni, dà la possibilità di dimensionare correttamente gli illuminamenti richiesti.

Le verifiche illuminotecniche sono possibili mediante le fotometrie disponibili, permettendo la massima espressione tecnica dei progettisti.

Essential geometries, lightness of form, minimalism and clean lines, infinite customizations offer the possibility to furnish all professional environments.

With MIKADO it is also possible to decorate technical environments respecting work needs and without forcing.

A slender line of light that allows to correctly size the required lighting thanks to its technicality and performance.

Lighting checks are possible using available photometries, so to allow the best technical expression of designers.



1x300 cm_Double emission light

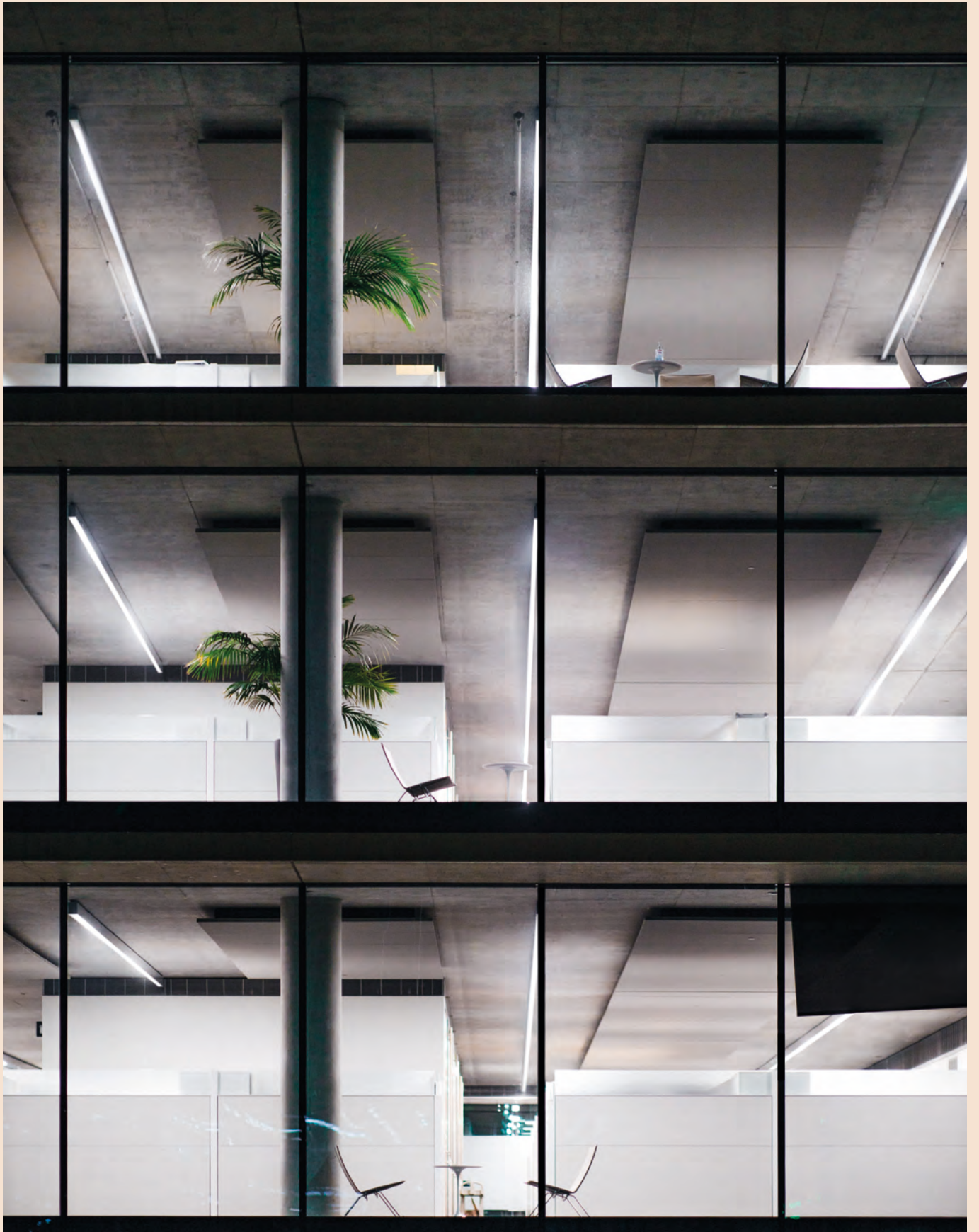

Multiple 300 cm_Down light



3x100 cm_Double emission light

MIKADO furniture

Decorativo e tecnico sono espressioni distanti che con MIKADO trovano una concreta e univoca collocazione nelle molteplici possibilità di installazione offerte.

I grandi ambienti sono l'ideale per intraprendere percorsi espressivi narrati con linee materiche e linee di luce, dove MIKADO trova vita come un lancio casuale o un ponderato disegno.

Modularità e flessibilità sono le parole chiave che identificano MIKADO non solo negli svariati disegni possibili, ma anche nelle infinite colorazioni personalizzabili delle strutture e del tipo di luce applicabili.

Creare architettura con la luce facendo quasi scomparirne la sorgente e, al contempo valorizzandone volumi ed arredi. Questo è il concept del sistema MIKADO.

Decorative and technical expressions are distant ones. MIKADO brings them together in a concrete and univocal collocation through the many installation possibilities that it offers.

Large rooms are the ideal space where material lines and lines of light can express themselves and where MIKADO comes to life as a casual throw or a reasoned design.

Modularity and flexibility are keywords that identify MIKADO: not only because of its various possible designs, but also for the infinite customizable colors of the structures and of the type of light.

To create architecture with light while making its source almost invisible and, at the same time, to enhance volumes and furnishings: this is the concept behind the MIKADO system.



Custom 2x120cm_Down light





Suspension composition_Double 3x200 cm_Double emission light
Multiple ceiling lamp_300 cm_Down light



Multiple ceiling lamp_300 cm_Down light
Multiple wall lamp Custom_300 cm_Double emission light



Multiple wall lamp Custom_Double emission light

LINE technical information

components and assembly possibilities:

horizontal possibilities:

- everywhere right&left
- 150cm to the wall

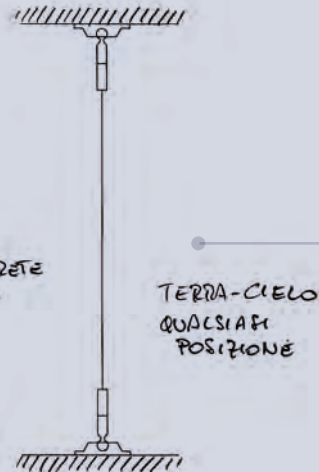
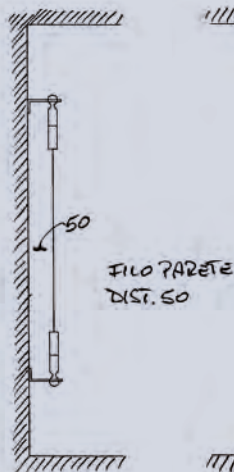
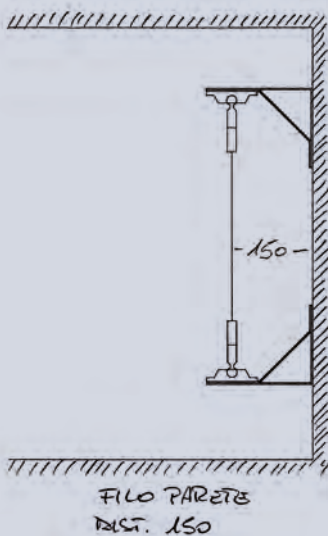
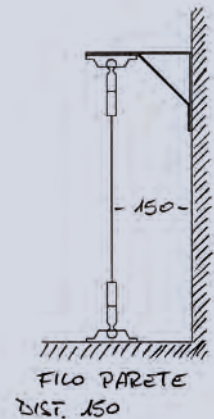
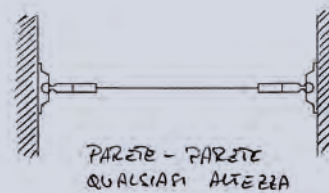

vertical possibilities:

- 150cm to the wall
- 50cm to the wall
- everywhere up&down

ceiling possibilities:

- everywhere right&left
- everywhere with wall attachment

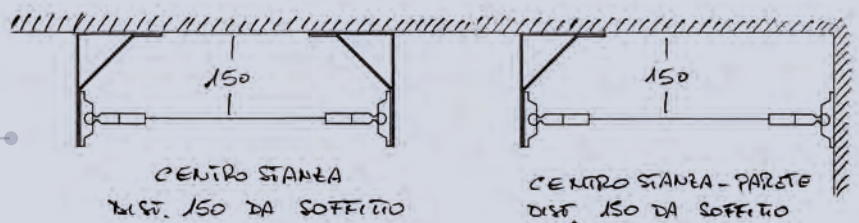

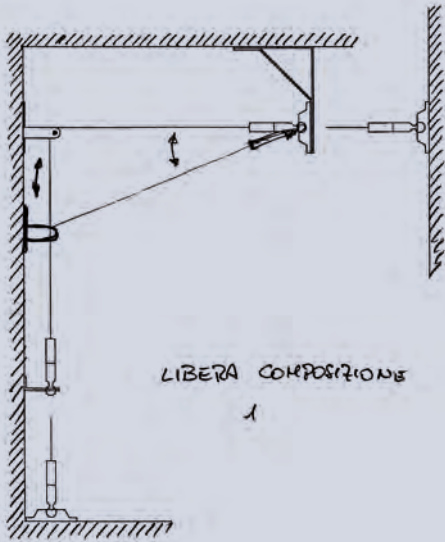

LIBERA COMPOSIZIONE
1

composition
type 1

possibility with
sloping roof

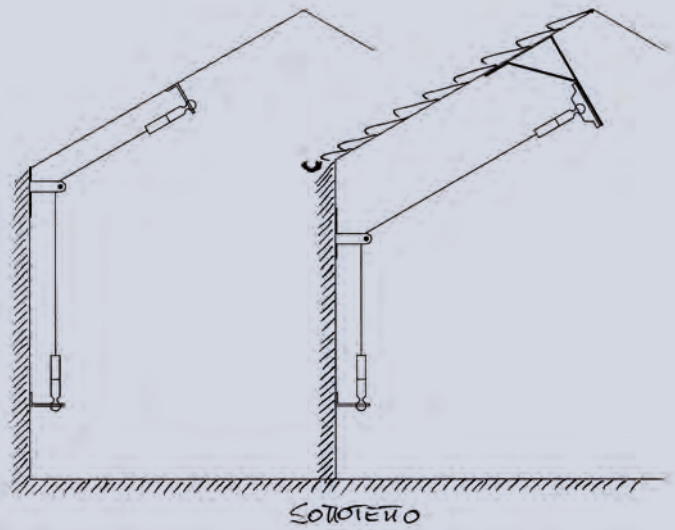

SOTTOTETTO

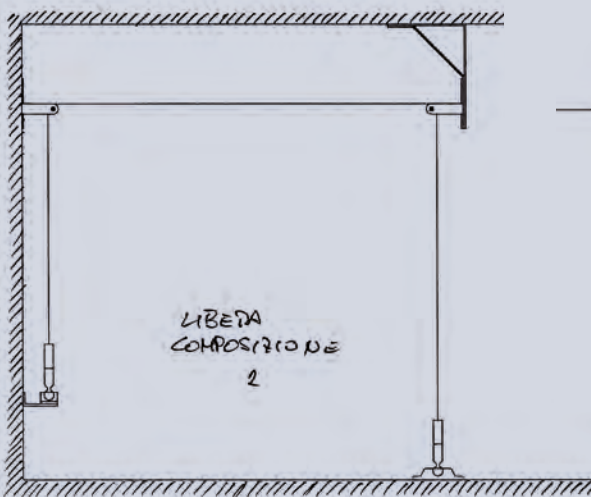

LIBERA
COMPOSIZIONE
2

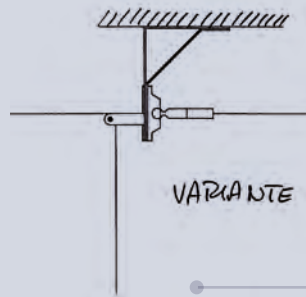

VARIANTE

composition
type 2



double emission

Max 19W + 14,4W mt
Max 3840 + 1100 lumen mt
Warm white light, daylight, cold, dinamic white WW/CW, RGBW



single emission

Max 24W mt
Max 3840 lumen mt
Warm white light, daylight, cold, dinamic white WW/CW, RGBW

Maximum sling length: 25 mt
Maximum horizontal span with intermediate support: 5 mt

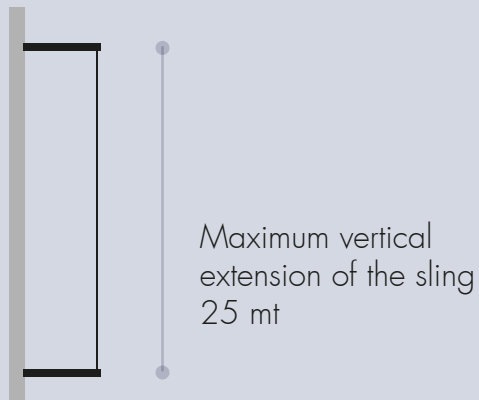
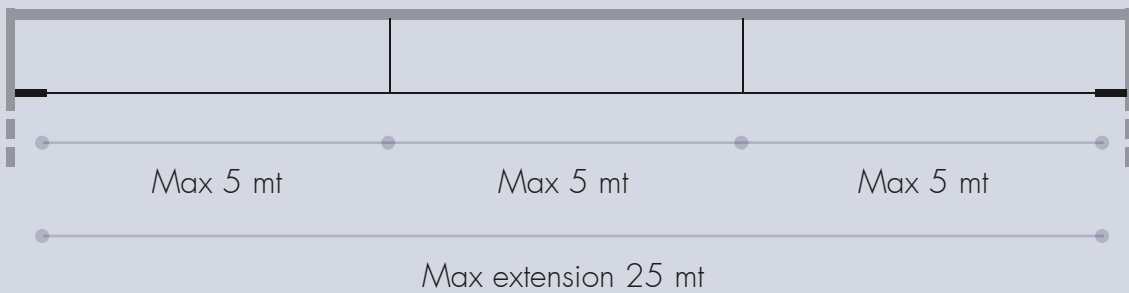

LINE elements:

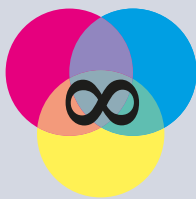
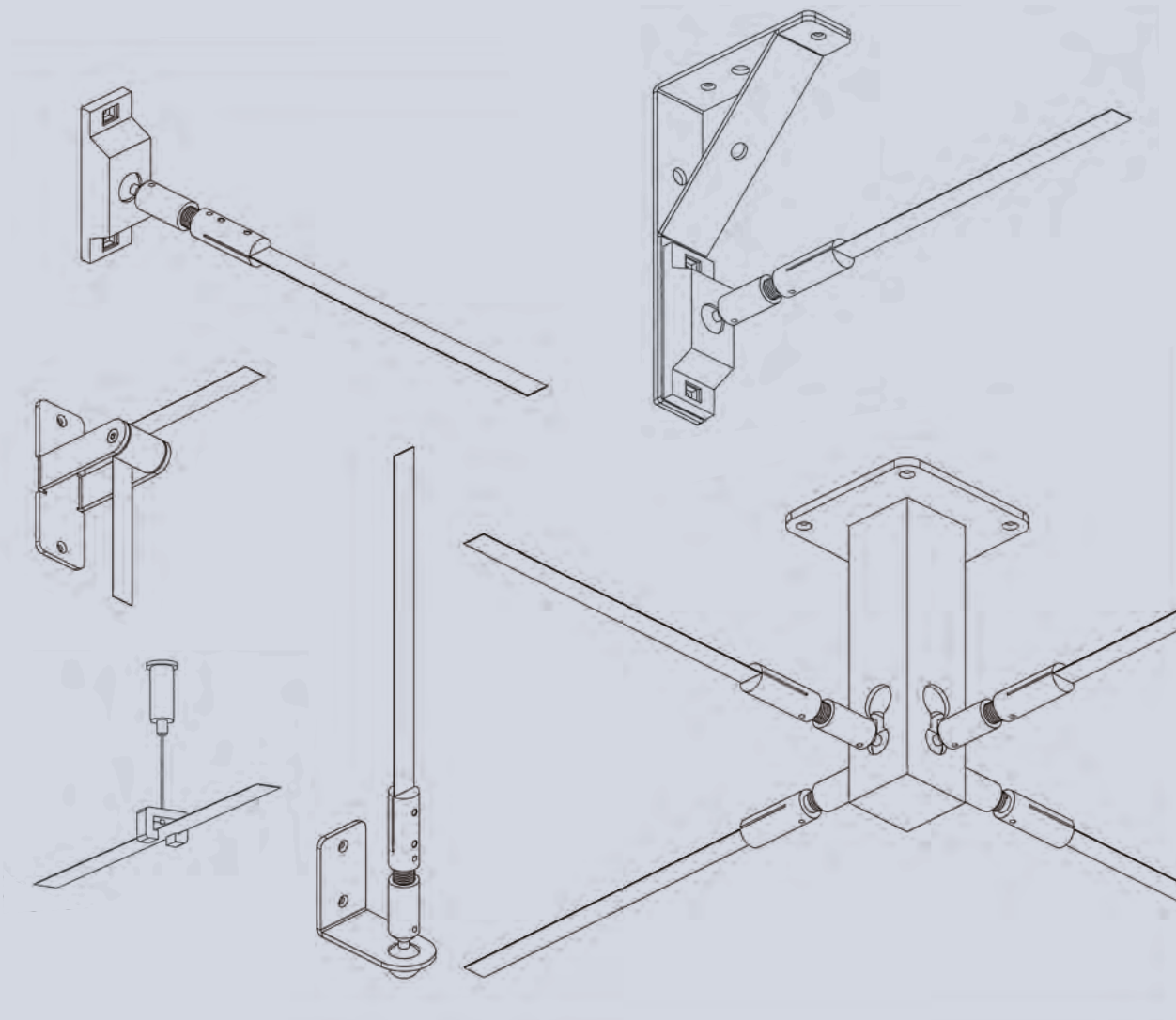

INFINITE possibilities of
temperature and light
gradation



Or

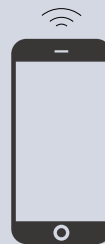

Complete
REMOTE CONTROL
for:
RGB control
dynamic white
power

MIKADO technical information

standard size:

100cm

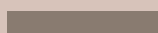

200cm



300cm



multiple size:

$300\text{cm} + 300\text{cm} + \dots = \infty$



custom size possibility



down light



Up&down light



up light



angle system for:
suspension, ceiling and wall lamp

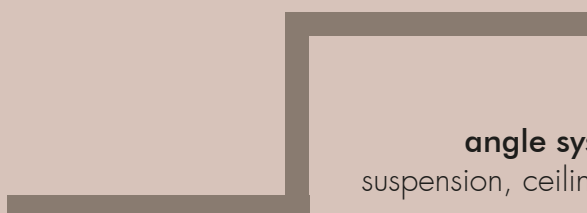

for direct illumination
max light
Trasparente



for indirect illumination
max uniform light
Opale

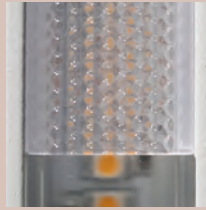

high light transmission
reduced glare UGR
Prismatica



max light diffusion
lateral spread
Opale Rialzata

Type COVER diffuser



UP light
MAX applicable power
24W x 1mt
3840 LUMEN x 1mt



DOWN light
MAX applicable power
24W x 1mt
3840 LUMEN x 1mt



MAX applicable FLOW
48W x 1mt
7680 LUMEN x 1mt

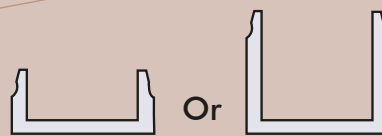
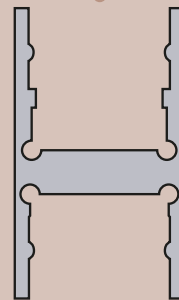
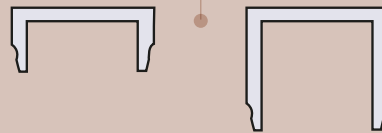

Max Light / Max Diffusion



finish with **INFINITE** colors
Matt or Gloss RAL

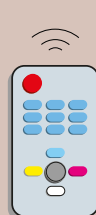

Or



Complete **REMOTE CONTROL**

for:
RGB control
dynamic white
power

Fisionarte srl

Sede legale:

Via della Liberazione, 32
31100 Treviso - ITALY

Sede operativa:

Viale delle Industrie, 5/A
31030 Dosson di Casier
Treviso - ITALY

T +39 331 229 7782
info@fisionarte.com

www.fisionarte.com

Il presente catalogo è proprietà dell'azienda FISIONARTE.
È vietata la riproduzione, la copia anche parziale e la diffusione
di questo documento attraverso qualsiasi mezzo (telematico,
fotocopia o altro) senza permesso scritto del proprietario.

This catalogue is property of FISIONARTE.
No part of this document may be reproduced or transmitted in
any form, by any means (electronic, photocopying, recording or
otherwise) without the prior written permission of the owner.

